

HANGER UTILITY SUPPORT
 WATER AND SEWER LINES
 3"=1'-0"

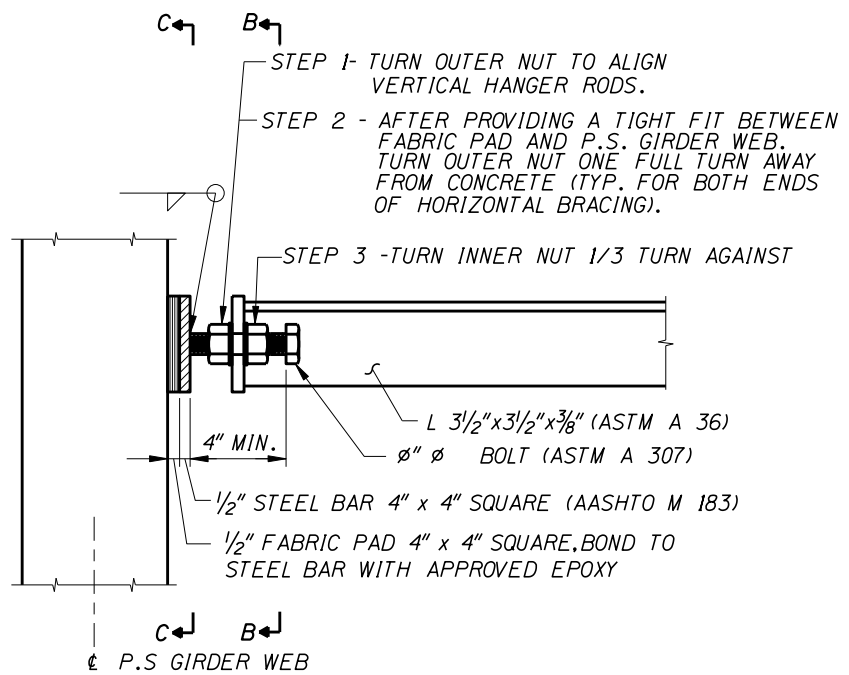

DETAIL A
 3"=1'-0"

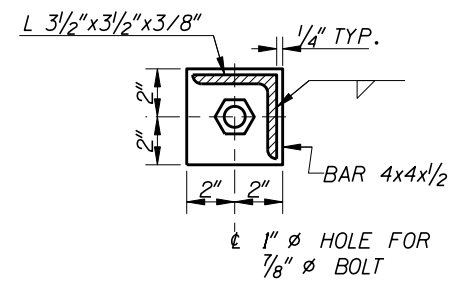

SECTION B
 3"=1'-0"

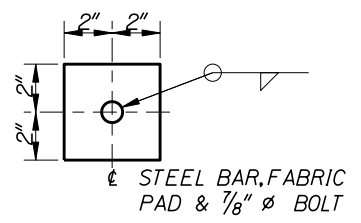

SECTION C
 3"=1'-0"

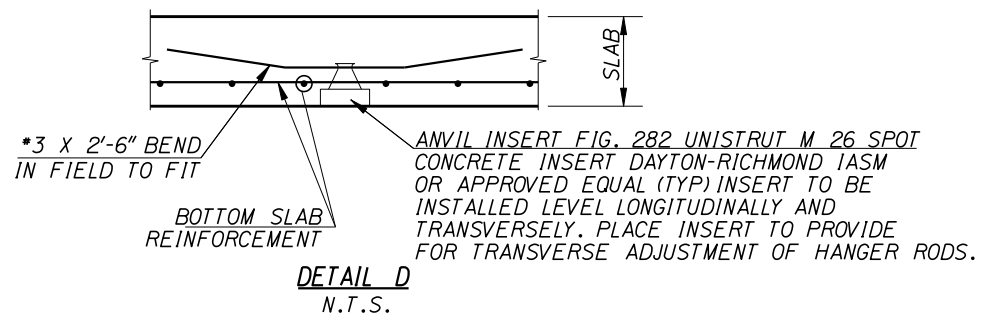

DETAIL D
 N.T.S.

REVISIONS			
NO.	DATE	BY	DESCRIPTION
△			
△			
△			
△			

DESIGNED
DESIGN CHECKED
DETAILED
DWG. CHECKED
CORRECTIONS

SCALES SHOWN ARE FOR 34" X 22" PRINTS ONLY
 CADD FILE NO. \\prj00000\bridge\b02_4a.dgn
 DRAWING DATE: JUNE 2006

ORIGINAL SIGNED BY: _____
 DATE SIGNED: DATE _____
 ORIGINAL STORED AT: ITO BRIDGE SECTION

IDAHO TRANSPORTATION DEPARTMENT



English
 PROJECT NO. _____

UTILITY HANGERS FOR PRESTRESSED GIRDER

BRIDGE PLANS
 BRIDGE LRFD MANUAL, PAGE B2.4A
 COUNTY _____ KEY NO. _____
 BRIDGE DRAWING NO. _____ SHEET _____ OF _____